



# STEAM PRESSURE REDUCING VALVE

## MODEL COSR-21

### SELF-ACTUATED PRESSURE REDUCING VALVE WITH SHOCK-ABSORBING PISTON

#### Features

**Technologically advanced pressure reducing valve for accurate control in process steam systems.**

1. Self-aligning shock-absorbing spherical piston and advanced pilot regulator designs maintain secondary steam pressure accuracy, even during adverse process conditions.
2. Major internal components made of stainless steel for long service life.
3. Large surface area integral screen for pilot valve extend trouble-free service.
4. Internal secondary pressure-sensing channel makes external sensing line unnecessary.
5. COSR-21, sizes 65 mm and larger have a silencer for noise reduction.



#### Specifications

Model	COSR-21	
Connection	Flanged	
Size (mm)	15, 20, 25, 32, 40, 50, 65, 80, 100	
Body Material	Ductile Cast Iron	
Maximum Operating Pressure (MPaG) PMO	2.1	
Maximum Operating Temperature (°C) TMO	220	
Primary Pressure Range (MPaG)	1.35 to 2.1	
Adjustable Pressure Range (all conditions must be met)	Within 10 to 84% of primary pressure but with a minimum pressure of 0.55 MPaG	
	Maximum differential pressure 0.85 MPa	
Minimum Adjustable Flow Rate	5% of rated flow rate (For 65 mm to 100 mm: 10% of rated flow rate)	

PRESSURE SHELL DESIGN CONDITIONS (NOT OPERATING CONDITIONS):

Maximum Allowable Pressure (MPaG) PMA: 2.1

Maximum Allowable Temperature (°C) TMA: 220

1 MPa = 10.197 kg/cm<sup>2</sup>



To avoid abnormal operation, accidents or serious injury, DO NOT use this product outside of the specification range. Local regulations may restrict the use of this product to below the conditions quoted.

### Configuration

No.	Description	Material	JIS	ASTM/AISI*
①	Main Body	Ductile Cast Iron	FCD450	A536
②	Cover	Ductile Cast Iron	FCD450	A536
③	Main Valve Seat	Stainless Steel	—	—
④	Main Valve	Stainless Steel	—	—
⑤	Main Valve Holder	Stainless Steel	—	—
⑥	Piston	Stainless Steel	—	—
⑦	Cylinder	Stainless Steel	—	—
⑧	Pilot Body	Ductile Cast Iron	FCD450	A536
⑨	Pilot Valve	Stainless Steel	—	—
⑩	Pilot Valve Seat	Stainless Steel	—	—
⑪	Diaphragm	Stainless Steel	—	—
⑫	Pilot Screen	Stainless Steel	—	—
⑬	Pilot Screen Holder	Carbon Steel	S25C	AISI1025
⑭	Diaphragm Support	Brass	—	—
⑮	Coil Spring	Carbon Steel	—	—
⑯	Spring Housing	Cast Iron	FC250	A126 Cl.B
⑰	Adjustment Screw	Cr-Mo Steel	—	—
⑱	Spanner Cap	Die Cast Aluminium	—	—
⑲	Plug – Sensing Line Port	Carbon Steel	SS400	A6
⑳	Pilot Cover	Ductile Cast Iron	FCD450	A536
㉑	Nameplate	Stainless Steel	—	—
㉒	Plug – Blow Line Port	Carbon Steel	SS400	A6
㉓	Silencer	Stainless Steel	—	—

\* Equivalent  
Contact TLV for available replacement parts. All gaskets are PTFE.

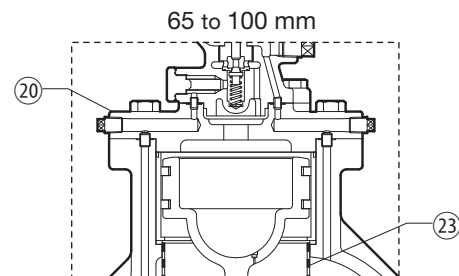
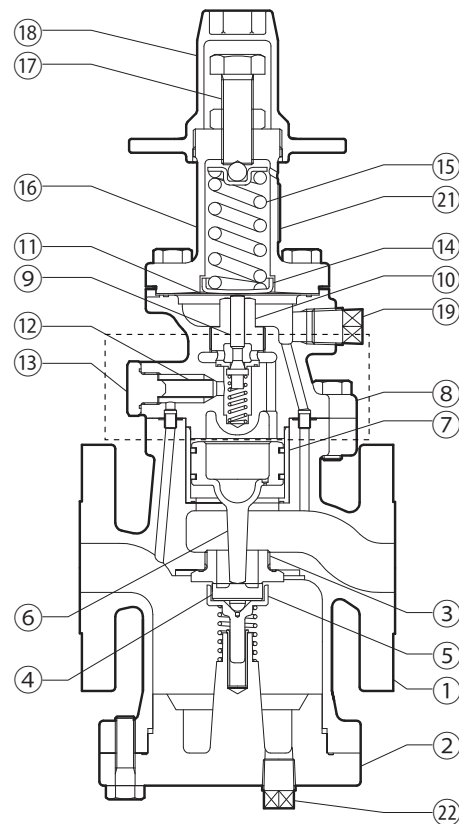

The parts configuration of sizes 65 to 100 mm differs slightly from that of sizes 15 to 50 mm.

### Cv Values

	Nominal Valve Size (mm)								
	15	20	25	32	40	50	65	80	100
Cv (US)	3.8	6.9	11.1	15.5	24.0	37.2	59.3	85.0	128
Cv (UK)	3.2	5.7	9.2	12.9	20.0	31.0	49.4	70.8	107
Kvs (DIN)	3.3	5.9	9.5	13.3	20.6	31.9	50.8	72.9	110



The Cv & Kvs values shown are for the valve in the full fail open position. These values are not to be used for COSR sizing, and instead may be used as one of the factors in calculations for safety valve selection.

### Sizing Chart

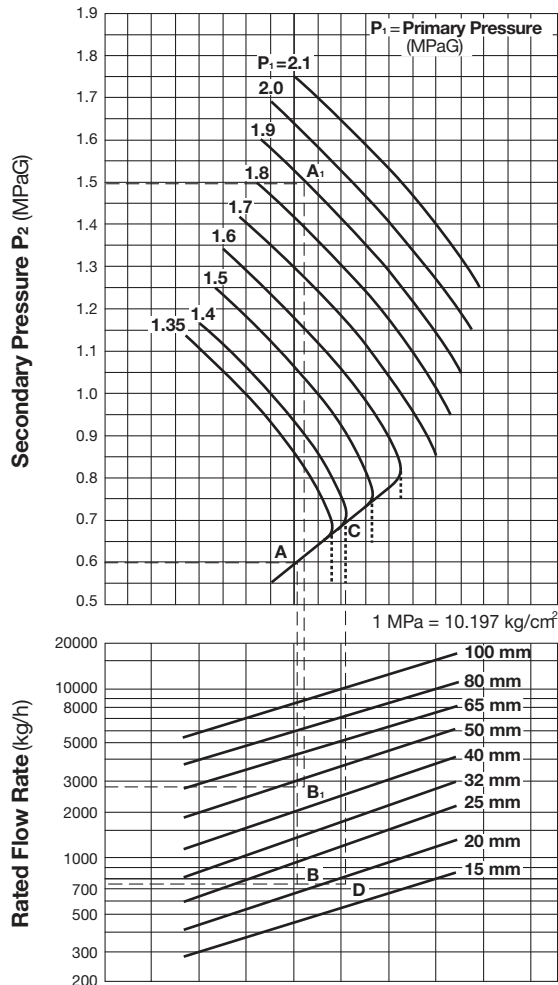

### Sizing Examples

#### For P1 over 1.6 MPaG

For primary pressure of 1.9 MPaG, set pressure 1.5 MPaG, and saturated steam flow rate 2800 kg/h, select an appropriate size.

1. Locate intersecting point A<sub>1</sub> of 1.9 MPaG primary pressure and 1.5 MPaG set pressure. Go to point A<sub>1</sub> and down until 2800 kg/h, point B<sub>1</sub> is reached.
2. Since point B<sub>1</sub> is located between 40 mm and 50 mm, the larger size, 50 mm, should be chosen.

#### Special Instructions for P1 under 1.6 MPaG

The vertical dotted lines in the graph represent the increased capacity often achievable when the internal sensing features of COSR-21 are enhanced by the installation of a 3/8 inch external secondary pressure-sensing line (condition: P<sub>2</sub> < 1/2 P<sub>1</sub>).

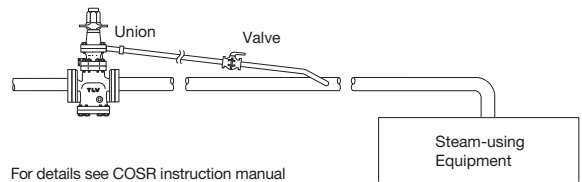

For details see COSR instruction manual

For primary pressure of 1.4 MPaG, set pressure 0.6 MPaG, and saturated steam flow rate 750 kg/h, select an appropriate size.

#### With internal secondary pressure-sensing channel

1. Locate intersecting point A of 1.4 MPaG primary pressure and 0.6 MPaG set pressure. Go to point A and down until 750 kg/h, point B, is reached.
2. Since point B is located between 20 mm and 25 mm, the larger size, 25 mm, should be chosen.

#### With external secondary pressure-sensing line

1. Obtain intersecting point C of 1.4 MPaG primary pressure. Go straight down from point C until 750 kg/h, point D, is reached.
2. Since point D is located between 15 mm and 20 mm, the larger size, 20 mm, should be chosen.

1 MPa = 10.197 kg/cm<sup>2</sup>

### Dimensions

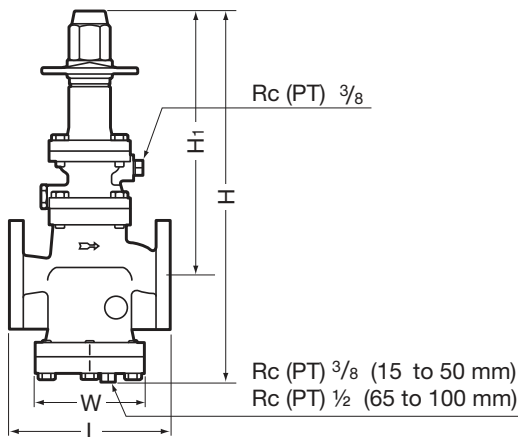

Size 15 to 50 mm shown. Configuration of larger sizes differs slightly.

### COSR-21 Flanged

Size	L		H	H <sub>1</sub>	W	Weight* (kg)
	ASME Class					
	150RF	300RF				
(15)	161	167	405	305	105	11
(20)	172	178				13
25	181	187	422	302	125	15
32	212	219	457	322	150	19
40	215	222				21
50	254	260	490	335	195	36
65	371	377	655	430	280	59
80	374	384				62
100	434	450	768	468	350	95

( ) No ASME standard exists for ductile cast iron; machined to fit steel flanges. Other standards available, but length and weight may vary.

\* Weight is for Class 300 RF

**Option**

<p>Pressure Gauge Unit</p>	<p>Replaces the standard screen holder plug to enable installation of a pressure gauge of the user's choice.                  Primary side: M16 holder plug (male/female), BSP/Rc(PT)/NPT <sup>3</sup>/<sub>8</sub>. An elbow is required for pressure gauge installation.                  Secondary side: Rc(PT) <sup>3</sup>/<sub>8</sub> mounting port for elbow and pressure gauge installation.</p>
<p>Elbows, pressure gauge and connecting parts must be purchased separately.</p>	

● **Configuration**

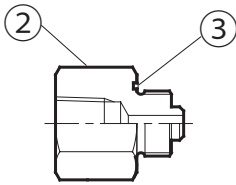

● **Installation Example**

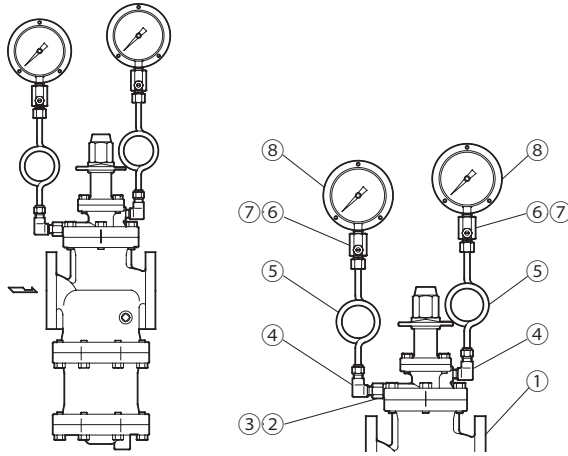

NOTE: For explanation purposes, a siphon tube style pressure gauge will be used. However, the instructions also apply to cooling tower-style pressure gauges.

No.	Part Name	No.	Part Name
1	Valve Body	5	Siphon Tube*
2	Holder Plug	6	Dampener*
3	Holder Plug Gasket	7	Dampener Gasket*
4	Elbow (male/female)*	8	Pressure Gauge*

\* Purchase separately

Manufacturer  
**TLV** CO., LTD.  
 Kakogawa, Japan  
is approved by LRQA Ltd. to ISO 9001/14001

ISO 9001  
 ISO 14001

